

PHILIPPINE BIDDING DOCUMENTS
(As Harmonized with Development Partners)

**Procurement of
INFRASTRUCTURE
PROJECTS**

Government of the Republic of the Philippines

Sixth Edition
July 2020

Preface

These Philippine Bidding Documents (PBDs) for the procurement of Infrastructure Projects (hereinafter referred to also as the “Works”) through Competitive Bidding have been prepared by the Government of the Philippines for use by all branches, agencies, departments, bureaus, offices, or instrumentalities of the government, including government-owned and/or -controlled corporations, government financial institutions, state universities and colleges, local government units, and autonomous regional government. The procedures and practices presented in this document have been developed through broad experience, and are for mandatory use in projects that are financed in whole or in part by the Government of the Philippines or any foreign government/foreign or international financing institution in accordance with the provisions of the 2016 revised Implementing Rules and Regulations (IRR) of Republic Act (RA) No. 9184.

The PBDs are intended as a model for admeasurements (unit prices or unit rates in a bill of quantities) types of contract, which are the most common in Works contracting.

The Bidding Documents shall clearly and adequately define, among others: (i) the objectives, scope, and expected outputs and/or results of the proposed contract; (ii) the eligibility requirements of Bidders; (iii) the expected contract duration; and (iv) the obligations, duties, and/or functions of the winning Bidder.

Care should be taken to check the relevance of the provisions of the PBDs against the requirements of the specific Works to be procured. If duplication of a subject is inevitable in other sections of the document prepared by the Procuring Entity, care must be exercised to avoid contradictions between clauses dealing with the same matter.

Moreover, each section is prepared with notes intended only as information for the Procuring Entity or the person drafting the Bidding Documents. They shall not be included in the final documents. The following general directions should be observed when using the documents:

- a. All the documents listed in the Table of Contents are normally required for the procurement of Infrastructure Projects. However, they should be adapted as necessary to the circumstances of the particular Project.
- b. Specific details, such as the “*name of the Procuring Entity*” and “*address for bid submission*,” should be furnished in the Instructions to Bidders, Bid Data Sheet, and Special Conditions of Contract. The final documents should contain neither blank spaces nor options.
- c. This Preface and the footnotes or notes in italics included in the Invitation to Bid, BDS, General Conditions of Contract, Special Conditions of Contract, Specifications, Drawings, and Bill of Quantities are not part of the text of the final document, although they contain instructions that the Procuring Entity should strictly follow.
- d. The cover should be modified as required to identify the Bidding Documents as to the names of the Project, Contract, and Procuring Entity, in addition to date of issue.

- e. Modifications for specific Procurement Project details should be provided in the Special Conditions of Contract as amendments to the Conditions of Contract. For easy completion, whenever reference has to be made to specific clauses in the Bid Data Sheet or Special Conditions of Contract, these terms shall be printed in bold typeface on Sections I (Instructions to Bidders) and III (General Conditions of Contract), respectively.

- f. For guidelines on the use of Bidding Forms and the procurement of Foreign-Assisted Projects, these will be covered by a separate issuance of the Government Procurement Policy Board.

TABLE OF CONTENTS

Glossary of Terms, Abbreviations, and Acronyms	5
Section I. Invitation to Bid.....	8
Section II. Instructions to Bidders	11
1. Scope of Bid.....	12
2. Funding Information	12
3. Bidding Requirements.....	12
4. Corrupt, Fraudulent, Collusive, Coercive, and Obstructive Practices	12
5. Eligible Bidders.....	12
6. Origin of Associated Goods	13
7. Subcontracts	13
8. Pre-Bid Conference.....	13
9. Clarification and Amendment of Bidding Documents.....	13
10. Documents Comprising the Bid: Eligibility and Technical Components.....	13
11. Documents Comprising the Bid: Financial Component	14
12. Alternative Bids	14
13. Bid Prices	14
14. Bid and Payment Currencies.....	15
15. Bid Security.....	15
16. Sealing and Marking of Bids.....	15
17. Deadline for Submission of Bids	15
18. Opening and Preliminary Examination of Bids	15
19. Detailed Evaluation and Comparison of Bids.....	16
20. Post Qualification.....	16
21. Signing of the Contract	16
Section III. Bid Data Sheet	17
Section IV. General Conditions of Contract.....	23
1. Scope of Contract.....	24
2. Sectional Completion of Works	24
3. Possession of Site	24
4. The Contractor's Obligations.....	24
5. Performance Security	25
6. Site Investigation Reports	25

7.	Warranty.....	25
8.	Liability of the Contractor.....	25
9.	Termination for Other Causes.....	25
10.	Dayworks	26
11.	Program of Work.....	26
12.	Instructions, Inspections and Audits	26
13.	Advance Payment.....	26
14.	Progress Payments	26
15.	Operating and Maintenance Manuals.....	26
	Section V. Special Conditions of Contract.....	28
	Section VI. Specifications	31
	Section VII. Drawings.....	34
	Section VIII. Bill of Quantities	38
	Section IX. Checklist of Technical and Financial Documents	43

Glossary of Terms, Abbreviations, and Acronyms

ABC – Approved Budget for the Contract.

ARCC – Allowable Range of Contract Cost.

BAC – Bids and Awards Committee.

Bid – A signed offer or proposal to undertake a contract submitted by a bidder in response to and in consonance with the requirements of the bidding documents. Also referred to as *Proposal* and *Tender*. (2016 revised IRR, Section 5[c])

Bidder – Refers to a contractor, manufacturer, supplier, distributor and/or consultant who submits a bid in response to the requirements of the Bidding Documents. (2016 revised IRR, Section 5[d])

Bidding Documents – The documents issued by the Procuring Entity as the bases for bids, furnishing all information necessary for a prospective bidder to prepare a bid for the Goods, Infrastructure Projects, and/or Consulting Services required by the Procuring Entity. (2016 revised IRR, Section 5[e])

BIR – Bureau of Internal Revenue.

BSP – Bangko Sentral ng Pilipinas.

CDA – Cooperative Development Authority.

Consulting Services – Refer to services for Infrastructure Projects and other types of projects or activities of the GOP requiring adequate external technical and professional expertise that are beyond the capability and/or capacity of the GOP to undertake such as, but not limited to: (i) advisory and review services; (ii) pre-investment or feasibility studies; (iii) design; (iv) construction supervision; (v) management and related services; and (vi) other technical services or special studies. (2016 revised IRR, Section 5[i])

Contract – Refers to the agreement entered into between the Procuring Entity and the Supplier or Manufacturer or Distributor or Service Provider for procurement of Goods and Services; Contractor for Procurement of Infrastructure Projects; or Consultant or Consulting Firm for Procurement of Consulting Services; as the case may be, as recorded in the Contract Form signed by the parties, including all attachments and appendices thereto and all documents incorporated by reference therein.

Contractor – is a natural or juridical entity whose proposal was accepted by the Procuring Entity and to whom the Contract to execute the Work was awarded. Contractor as used in these Bidding Documents may likewise refer to a supplier, distributor, manufacturer, or consultant.

CPI – Consumer Price Index.

DOLE – Department of Labor and Employment.

DTI – Department of Trade and Industry.

Foreign-funded Procurement or Foreign-Assisted Project –Refers to procurement whose funding source is from a foreign government, foreign or international financing institution as specified in the Treaty or International or Executive Agreement. (2016 revised IRR, Section 5[b]).

GFI – Government Financial Institution.

GOCC –Government-owned and/or –controlled corporation.

Goods – Refer to all items, supplies, materials and general support services, except Consulting Services and Infrastructure Projects, which may be needed in the transaction of public businesses or in the pursuit of any government undertaking, project or activity, whether in the nature of equipment, furniture, stationery, materials for construction, or personal property of any kind, including non-personal or contractual services such as the repair and maintenance of equipment and furniture, as well as trucking, hauling, janitorial, security, and related or analogous services, as well as procurement of materials and supplies provided by the Procuring Entity for such services. The term “related” or “analogous services” shall include, but is not limited to, lease or purchase of office space, media advertisements, health maintenance services, and other services essential to the operation of the Procuring Entity. (2016 revised IRR, Section 5[r])

GOP – Government of the Philippines.

Infrastructure Projects – Include the construction, improvement, rehabilitation, demolition, repair, restoration or maintenance of roads and bridges, railways, airports, seaports, communication facilities, civil works components of information technology projects, irrigation, flood control and drainage, water supply, sanitation, sewerage and solid waste management systems, shore protection, energy/power and electrification facilities, national buildings, school buildings, hospital buildings, and other related construction projects of the government. Also referred to as *civil works or works*. (2016 revised IRR, Section 5[u])

LGUs – Local Government Units.

NFCC – Net Financial Contracting Capacity.

NGA – National Government Agency.

PCAB – Philippine Contractors Accreditation Board.

PhilGEPS - Philippine Government Electronic Procurement System.

Procurement Project – refers to a specific or identified procurement covering goods, infrastructure project or consulting services. A Procurement Project shall be described, detailed, and scheduled in the Project Procurement Management Plan prepared by the agency which shall be consolidated in the procuring entity's Annual Procurement Plan. (GPPB Circular No. 06-2019 dated 17 July 2019)

PSA – Philippine Statistics Authority.

SEC – Securities and Exchange Commission.

SLCC – Single Largest Completed Contract.

UN – United Nations.

Section I. Invitation to Bid

Notes on the Invitation to Bid

The Invitation to Bid (IB) provides information that enables potential Bidders to decide whether to participate in the procurement at hand. The IB shall be posted in accordance with Section 21.2 of the 2016 revised IRR of RA No. 9184.

Apart from the essential items listed in the Bidding Documents, the IB should also indicate the following:

- a. The date of availability of the Bidding Documents, which shall be from the time the IB is first advertised/posted until the deadline for the submission and receipt of bids;
- b. The place where the Bidding Documents may be acquired or the website where it may be downloaded;
- c. The deadline for the submission and receipt of bids; and
- d. Any important bid evaluation criteria.

The IB should be incorporated into the Bidding Documents. The information contained in the IB must conform to the Bidding Documents and in particular to the relevant information in the Bid Data Sheet.

REPUBLIC OF THE PHILIPPINES
MUNICIPALITY OF MARIVELES
MARIVELES, BATAAN

INVITATION TO BID FOR COMPLETION OF MULTI-PURPOSE BUILDING AT BARANGAY MALIGAYA MARIVELES, BATAAN

1. The *LGU-Mariveles*, through the *Budget of the Contract Approved by the Sanggunian of 2023* intends to apply the sum of *Seven Hundred Thousand Pesos (Php700,000.00)* being the Approved Budget for the Contract (ABC) to payments under the contract for *Completion of Multi-Purpose Building at Barangay Maligaya Mariveles, Bataan*. Bids received in excess of the ABC shall be automatically rejected at bid opening.
2. The *LGU-Mariveles* now invites bids for the above Procurement Project. Completion of the Works is required *within 24 calendar days upon receipt of the Notice to Proceed*. Bidders should have completed a contract similar to the Project. The description of an eligible bidder is contained in the Bidding Documents, particularly, in Section II (Instructions to Bidders).
3. Bidding will be conducted through open competitive bidding procedures using non-discretionary “*pass/fail*” criterion as specified in the 2016 revised Implementing Rules and Regulations (IRR) of Republic Act (RA) No. 9184.
4. Interested bidders may obtain further information from *Secretariat Office/Procurement Unit, Municipal Hall Compound Mariveles, Bataan* and inspect the Bidding Documents at the address given below from *8:00-5:00p.m., weekdays except holidays*.
5. A complete set of Bidding Documents may be acquired by interested bidders on *May 24, 2023 until 10:00a.m. of June 13, 2023* from given address and website/below and upon payment of the applicable fee for the Bidding Documents, pursuant to the latest Guidelines issued by the GPPB, in the amount of *One Thousand Pesos (Php1,000.00)*. The Procuring Entity shall allow the bidder to present its proof of payment for the fees in person, by facsimile, or through electronic means.
6. The *LGU-Mariveles* will hold a Pre-Bid Conference on *May 31, 2023 at 10:00 a.m.* at *Municipal Conference Room, Municipal Hall Compound Mariveles, Bataan* which shall be open to prospective bidders.
7. Bids must be duly received by the BAC Secretariat through manual submission at the office address as indicated below on or before *12:00nn., June 13, 2023*. Late bids shall not be accepted.
8. All bids must be accompanied by a bid security in any of the acceptable forms and in the amount stated in **ITB** Clause 16.

9. Bid opening shall be on **June 13, 2023 at 2:00p.m.** at the given address below. Bid will be opened in the presence of the bidders' representatives who choose to attend the activity.

10. The schedule of the procurement activities shall be as follow:

Procurement Activity	Date and Time	Venue/Remarks
Advertisement / Availability of Bid Documents	May 24, 2023 until 10:00a.m. of June 13, 2023	LGU and PhilGEPS website
Pre-bid Conference	May 31, 2023 at 10:00a.m.	Municipal Conference Room
Site Inspection	June 01, 2023 at 1:00 p.m. - 3:00 p.m..	<i>Barangay Maligaya Mariveles, Bataan</i>
Last day for submission of written clarifications	At least 10 days before the deadline of submission of bids	Bids and Awards Committee Secretariat Office and lgu_bacmariveles@yahoo.com.ph
Last day for issuance of bid bulletins	At Least 7 days before the opening of bids	BAC Secretariat Office, LGU and PhilGEPS website
Deadline for submission of bids	Until 12:00n.n. of June 13, 2023	BAC Secretariat Office
Opening of Bids	2:00p.m. of June 13, 2023	Municipal Conference Room

11. The **LGU-Mariveles** reserves the right to reject any and all bids, declare a failure of bidding, or not award the contract at any time prior to contract award in accordance with Sections 35.6 and 41 of the 2016 revised Implementing Rules and Regulations (IRR) of RA No. 9184, without thereby incurring any liability to the affected bidder or bidders.

12. For further information, please refer to:

*Secretariat Office/Procurement Unit
 LGU – Mariveles
 Municipal Hall Compound
 Poblacion Mariveles, Bataan
 Tel. No. (047) 935-4620
 Email address: lgu_bacmariveles@yahoo.com.ph*

13. You may visit the website for downloading Bidding Documents: marivelesbataan.gov.ph

[Date of Issue]

Engr. Chito L. Riego de Dios
BAC, Chairperson

Section II. Instructions to Bidders

Notes on the Instructions to Bidders

This Section on the Instruction to Bidders (ITB) provides the information necessary for bidders to prepare responsive bids, in accordance with the requirements of the Procuring Entity. It also provides information on bid submission, eligibility check, opening and evaluation of bids, post-qualification, and on the award of contract.

1. Scope of Bid

The Procuring Entity, *LGU-Mariveles* invites Bids for the *Completion of Multi-Purpose Building at Barangay Maligaya Mariveles, Bataan* with Project Identification Number *CW2023-05-011*.

The Procurement Project (referred to herein as “Project”) is for the construction of Works, as described in Section VI (Specifications).

2. Funding Information

2.1. The GOP through the source of funding as indicated below for 2023 in the amount of *Seven Hundred Thousand Pesos (Php700,000.00)*.

2.2. The source of funding is:

a. LGUs, the Annual or Supplemental Budget, as approved by the Sanggunian.

3. Bidding Requirements

The Bidding for the Project shall be governed by all the provisions of RA No. 9184 and its 2016 revised IRR, including its Generic Procurement Manual and associated policies, rules and regulations as the primary source thereof, while the herein clauses shall serve as the secondary source thereof.

Any amendments made to the IRR and other GPPB issuances shall be applicable only to the ongoing posting, advertisement, or invitation to bid by the BAC through the issuance of a supplemental or bid bulletin.

The Bidder, by the act of submitting its Bid, shall be deemed to have inspected the site, determined the general characteristics of the contracted Works and the conditions for this Project, such as the location and the nature of the work; (b) climatic conditions; (c) transportation facilities; (c) nature and condition of the terrain, geological conditions at the site communication facilities, requirements, location and availability of construction aggregates and other materials, labor, water, electric power and access roads; and (d) other factors that may affect the cost, duration and execution or implementation of the contract, project, or work and examine all instructions, forms, terms, and project requirements in the Bidding Documents.

4. Corrupt, Fraudulent, Collusive, Coercive, and Obstructive Practices

The Procuring Entity, as well as the Bidders and Contractors, shall observe the highest standard of ethics during the procurement and execution of the contract. They or through an agent shall not engage in corrupt, fraudulent, collusive, coercive, and obstructive practices defined under Annex “I” of the 2016 revised IRR of RA No. 9184 or other integrity violations in competing for the Project.

5. Eligible Bidders

- 5.1. Only Bids of Bidders found to be legally, technically, and financially capable will be evaluated.
- 5.2. The Bidder must have an experience of having completed a Single Largest Completed Contract (SLCC) that is similar to this Project, equivalent to at least fifty percent (50%) of the ABC adjusted, if necessary, by the Bidder to current prices using the PSA's CPI, except under conditions provided for in Section 23.4.2.4 of the 2016 revised IRR of RA No. 9184.

A contract is considered to be "similar" to the contract to be bid if it has the major categories of work stated in the **BDS**.
- 5.3. For Foreign-funded Procurement, the Procuring Entity and the foreign government/foreign or international financing institution may agree on another track record requirement, as specified in the Bidding Document prepared for this purpose.
- 5.4. The Bidders shall comply with the eligibility criteria under Section 23.4.2 of the 2016 IRR of RA No. 9184.

6. Origin of Associated Goods

There is no restriction on the origin of Goods other than those prohibited by a decision of the UN Security Council taken under Chapter VII of the Charter of the UN.

7. Subcontracts

7.1 The Procuring Entity has prescribed that subcontracting is not allowed.

8. Pre-Bid Conference

The Procuring Entity will hold a pre-bid conference for this Project on the specified date and time and either at its physical address and/or through videoconferencing/webcasting as indicated in paragraph 6 of the **IB**.

9. Clarification and Amendment of Bidding Documents

Prospective bidders may request for clarification on and/or interpretation of any part of the Bidding Documents. Such requests must be in writing and received by the Procuring Entity, either at its given address or through electronic mail indicated in the **IB**, at least ten (10) calendar days before the deadline set for the submission and receipt of Bids.

10. Documents Comprising the Bid: Eligibility and Technical Components

10.1. The first envelope shall contain the eligibility and technical documents of the Bid as specified in **Section IX. Checklist of Technical and Financial Documents**.

- 10.2. If the eligibility requirements or statements, the bids, and all other documents for submission to the BAC are in foreign language other than English, it must be accompanied by a translation in English, which shall be authenticated by the appropriate Philippine foreign service establishment, post, or the equivalent office having jurisdiction over the foreign bidder's affairs in the Philippines. For Contracting Parties to the Apostille Convention, only the translated documents shall be authenticated through an apostille pursuant to GPPB Resolution No. 13-2019 dated 23 May 2019. The English translation shall govern, for purposes of interpretation of the bid.
- 10.3. A valid PCAB License is required, and in case of joint ventures, a valid special PCAB License, and registration for the type and cost of the contract for this Project. Any additional type of Contractor license or permit shall be indicated in the **BDS**.
- 10.4. A List of Contractor's key personnel (e.g., Project Manager, Project Engineers, Materials Engineers, and Foremen) assigned to the contract to be bid, with their complete qualification and experience data shall be provided. These key personnel must meet the required minimum years of experience set in the **BDS**.
- 10.5. A List of Contractor's major equipment units, which are owned, leased, and/or under purchase agreements, supported by proof of ownership, certification of availability of equipment from the equipment lessor/vendor for the duration of the project, as the case may be, must meet the minimum requirements for the contract set in the **BDS**.

11. Documents Comprising the Bid: Financial Component

- 11.1. The second bid envelope shall contain the financial documents for the Bid as specified in **Section IX. Checklist of Technical and Financial Documents**.
- 11.2. Any bid exceeding the ABC indicated in paragraph 1 of the **IB** shall not be accepted.
- 11.3. For Foreign-funded procurement, a ceiling may be applied to bid prices provided the conditions are met under Section 31.2 of the 2016 revised IRR of RA No. 9184.

12. Alternative Bids

Bidders shall submit offers that comply with the requirements of the Bidding Documents, including the basic technical design as indicated in the drawings and specifications. Unless there is a value engineering clause in the **BDS**, alternative Bids shall not be accepted.

13. Bid Prices

All bid prices for the given scope of work in the Project as awarded shall be considered as fixed prices, and therefore not subject to price escalation during contract implementation, except under extraordinary circumstances as determined by the NEDA

and approved by the GPPB pursuant to the revised Guidelines for Contract Price Escalation guidelines.

14. Bid and Payment Currencies

14.1. Bid prices may be quoted in the local currency or tradeable currency accepted by the BSP at the discretion of the Bidder. However, for purposes of bid evaluation, Bids denominated in foreign currencies shall be converted to Philippine currency based on the exchange rate as published in the BSP reference rate bulletin on the day of the bid opening.

14.2. Payment of the contract price shall be made in **Philippine Pesos**.

15. Bid Security

15.1. The Bidder shall submit a Bid Securing Declaration or any form of Bid Security in the amount indicated in the **BDS**, which shall be not less than the percentage of the ABC in accordance with the schedule in the **BDS**.

15.2. The Bid and bid security shall be valid until *120 calendar days after the opening of bids*. Any bid not accompanied by an acceptable bid security shall be rejected by the Procuring Entity as non-responsive.

16. Sealing and Marking of Bids

Each Bidder shall submit one copy of the first and second components of its Bid.

The Procuring Entity may request additional hard copies and/or electronic copies of the Bid. However, failure of the Bidders to comply with the said request shall not be a ground for disqualification.

If the Procuring Entity allows the submission of bids through online submission to the given website or any other electronic means, the Bidder shall submit an electronic copy of its Bid, which must be digitally signed. An electronic copy that cannot be opened or is corrupted shall be considered non-responsive and, thus, automatically disqualified.

17. Deadline for Submission of Bids

The Bidders shall submit on the specified date and time and either at its physical address or through online submission as indicated in paragraph 7 of the **IB**.

18. Opening and Preliminary Examination of Bids

18.1. The BAC shall open the Bids in public at the time, on the date, and at the place specified in paragraph 9 of the **IB**. The Bidders' representatives who are present shall sign a register evidencing their attendance. In case videoconferencing, webcasting or other similar technologies will be used, attendance of participants shall likewise be recorded by the BAC Secretariat.

In case the Bids cannot be opened as scheduled due to justifiable reasons, the rescheduling requirements under Section 29 of the 2016 revised IRR of RA No. 9184 shall prevail.

- 18.2. The preliminary examination of Bids shall be governed by Section 30 of the 2016 revised IRR of RA No. 9184.

19. Detailed Evaluation and Comparison of Bids

- 19.1. The Procuring Entity's BAC shall immediately conduct a detailed evaluation of all Bids rated "*passed*" using non-discretionary pass/fail criteria. The BAC shall consider the conditions in the evaluation of Bids under Section 32.2 of 2016 revised IRR of RA No. 9184.
- 19.2. If the Project allows partial bids, all Bids and combinations of Bids as indicated in the **BDS** shall be received by the same deadline and opened and evaluated simultaneously so as to determine the Bid or combination of Bids offering the lowest calculated cost to the Procuring Entity. Bid Security as required by **ITB** Clause 16 shall be submitted for each contract (lot) separately.
- 19.3. In all cases, the NFCC computation pursuant to Section 23.4.2.6 of the 2016 revised IRR of RA No. 9184 must be sufficient for the total of the ABCs for all the lots participated in by the prospective Bidder.

20. Post Qualification

Within a non-extendible period of five (5) calendar days from receipt by the Bidder of the notice from the BAC that it submitted the Lowest Calculated Bid, the Bidder shall submit its latest income and business tax returns filed and paid through the BIR Electronic Filing and Payment System (e FPS), and other appropriate licenses and permits required by law and stated in the **BDS**.

21. Signing of the Contract

The documents required in Section 37.2 of the 2016 revised IRR of RA No. 9184 shall form part of the Contract. Additional Contract documents are indicated in the **BDS**.

Section III. Bid Data Sheet

Notes on the Bid Data Sheet (BDS)

The Bid Data Sheet (BDS) consists of provisions that supplement, amend, or specify in detail, information, or requirements included in the ITB found in Section II, which are specific to each procurement.

This Section is intended to assist the Procuring Entity in providing the specific information in relation to corresponding clauses in the ITB and has to be prepared for each specific procurement.

The Procuring Entity should specify in the BDS information and requirements specific to the circumstances of the Procuring Entity, the processing of the procurement, and the bid evaluation criteria that will apply to the Bids. In preparing the BDS, the following aspects should be checked:

- a. Information that specifies and complements provisions of the ITB must be incorporated.
- b. Amendments and/or supplements, if any, to provisions of the ITB as necessitated by the circumstances of the specific procurement, must also be incorporated.

Bid Data Sheet

ITB Clause				
5.2	<p>For this purpose, contracts similar to the Project refer to contracts which have the same major categories of work, which shall be construction of building structures.</p> <p>The works shall consist of:</p> <ol style="list-style-type: none"> 1. Project Billboard /Sign Board 2. Occupational Safety and Health Program 3. Mobilization and Demobilization 4. Wall Tiles (Glazed Tiles and Trims) 5. Floor Tiles (Unglazed Tiles and Trims) 6. Hardiflex on Metal Frame Ceiling 7. Electrical Works 8. Metal Railings / Window Grills 9. Painting Works (Masonry Painting) 10. Painting Works (Ceiling) 11. Painting Works (Metal Painting) 12. Aluminum Glass Door (Sliding /Awning) <p>Scope of works in the submitted SLCC which are not listed above shall not be considered in the calculation of the SLCC requirement.</p>			
7.1	<i>Subcontracting is not allowed.</i>			
10.3	Prospective bidders must have at least a license category “AAA and a license classification “Large B” from the Philippine Contractors Accreditation Board (PCAB) for General Engineering (GE-1). The PCAB license must be valid and effective at the time of submission of the bid.			
10.4	The key personnel must meet the required minimum years of experience set below:			
	No.	Key Personnel	Qualifications/Relevant Experience	Minimum Required
	1	Project Engineer	Must be a Licensed Civil Engineer with 5-year minimum experience as Project Engineer for building construction.	1
	2	Materials Engineer	Must be a DPWH Accredited Materials Engineer with 1-year minimum experience as Material Engineer	1
	3	Site Engineer	(Must be a Licensed Civil Engineer with	1

		5-year minimum experience as Site Engineer for Building Construction	
4	Health and Safety Officer	Must be a DOLE-accredited Safety Officer for at least five (5) years and with at least three (3) years of experience as DOLE accredited Health and Safety Officer.	1
5	First Aider	Must have a valid “Standard First Aid and Basic Life Support” training certificate issued by Red Cross with at least 1 year experience as first aider	1
6	Foreman	Must have a 3 years minimum experience as a Foreman in building construction	1

The bidder is not allowed to combine work experiences of two or more personnel in order to meet the required minimum years of experience.

The bidder is not allowed to nominate a person more than once.

The licenses of the nominated key personnel must be valid during the submission of bids.

The list must be supported by the following documents:

- 1.) Individual resumes to show proof of the following:
 - a.) that the proposed personnel meets the required relevant experience;
 - b.) list of projects handled with the corresponding position and its inclusive years of experience (e.g. Construction of Roads and/or Site Development Project Manager, 2012-2017).
- 2.) Photocopy of PRC Licenses/DOLE-OHSC/DPWH Accreditation. Expired PRC License may be accepted provided that the proof for the renewal of application is attached. Valid and renewed PRC license of all key personnel assigned must be submitted during Post-Qualification.

10.5	The minimum major equipment requirements are the following:		
	<u>No</u>	<u>Type of Equipment</u>	<u>Number of Units</u>
	1.	Truck	1
	2.	Service Vehicle	1

	<p>3. Welding Machine 1</p> <p>4. Grinder 1</p> <p>Acceptable proof of ownership/leased/under purchase agreement:</p> <ol style="list-style-type: none"> 1.) If owned, supported by proof of ownership such as but not limited to: <ol style="list-style-type: none"> a.) Official Receipt b.) Deed of Sale c.) OR/CR d.) Sales invoice showing payment of VAT e.) Proforma invoice supported by a Sales Invoice f.) Letter of Credit from bank with attached Purchase Order supported by a Sales Invoice g.) Acknowledgement Receipt from Supplier h.) Commercial Receipt/Commercial Invoice i.) Original Invoice with attached Packing List j.) Bill of Lading k.) Collection Receipt l.) Delivery Receipt and Certificate of Availability of Key Personnel and Equipment to certify its availability for the duration of the project. 2.) If lease, Lease Agreement between lessor and lessee, Proof of Ownership of the Lessor to be included in the Technical Proposal and Certificate of Availability of the Equipment from the Lessor for the duration of the project 3.) If under Purchase Agreement, Purchase Agreement between the bidder and the owner and Certificate of Availability of the Equipment from the vendor for the duration of the project.
11.1	<p>In addition to the Bid form and Bill of Quantities, the following shall be included in the Financial Component:</p> <ol style="list-style-type: none"> 1.) Detailed estimates, including a summary sheet (Dayworks Form) indicating the unit prices of construction materials, labor rates, and equipment rentals used in coming up with the Bid considering 12% VAT; and 2.) Cash flow by quarter or payment schedule. <p>Notes:</p> <ol style="list-style-type: none"> 1.) Bidders with incomplete submission and/or omissions shall be disqualified. 2.) In filling out the bid form, bidders shall provide a discount offer in the form of amount, in figures and in words, including its application and methodology. In case of no discount offered, bidders shall write “none.” 3.) For the bill of quantities, in case of any discrepancies between the editable (excel) version and PDF version, the latter shall govern. The BAC and the procuring entity are not responsible for any omissions made by the bidder in accomplishing this form.
12	<p><i>[Insert Value Engineering clause if allowed.] ***no further instruction***</i></p>
15.1	<p>The bid security shall be in the form of a Bid Securing Declaration or any of the following forms and amounts:</p> <ol style="list-style-type: none"> a. The amount of not less than Php14,000.00 [(2%) of ABC], if bid security is in cash, cashier’s/manager’s check, bank draft/guarantee or irrevocable letter of credit;

	b. The amount of not less than Php35,000.00 [(5%) of ABC] if bid security is in Surety Bond.
16	Each bidder shall submit one (1) original hardcopy and two (2) hardcopies of its bid.
19.2	Partial bid is not allowed. The infrastructure project is packaged in a single lot and the lot shall not be divided into sub-lots for the purpose of bidding, evaluation, and contract award.
20	<p>For purposes of Post-Qualification the following documents(s) shall be required to be submitted within five (5) calendar days from receipt of notice from the BAC:</p> <ol style="list-style-type: none"> 1.) Income Tax Returns for year 2021 (BIR Form 1701 or 1702); 2.) Latest Value Added Tax Returns (Forms 2550M and 2550Q) or Percentage Tax Returns (Form 2551M) for the last six (6) months (November 2021 – April 2022) before the deadline of the submission of bids. The income tax and business tax returns stated above should have been filed through the Electronic Filing and Payment System (e FPS). 3.) Proof of Ongoing and Awarded Contracts but not yet started as identified in the Statement of All Ongoing Government & Private Contracts, which shall include the following: <ol style="list-style-type: none"> a.) Notice to Proceed or equivalent; and b.) Certificate of accomplishments signed by the Owner or Owner’s Project Engineer or in case the project was just awarded or still in the mobilization stage, a certification in lieu of the certificate of accomplishment signed by the Owner or Owner’s Project Engineer should be submitted. 4.) Valid and updated PhilGEPS Certificate of Registration (Platinum Membership) during opening of bids. 5.) Valid PRC licenses of key personnel assigned (if the bidder opt to submit expired PRC license together with the proof of renewal during the opening of bids. 6.) One (1) softcopy of its original bid in PDF format, in case of discrepancies and technical issues in the submitted drive, it shall not be a ground for disqualification and the original hardcopy shall prevail in terms of its contents. 7.) Detailed Bill of Quantities of Single Largest Completed Contract showing breakdown of cost for categories of works listed under BDS 5.2.

21	Additional contract documents relevant to the Project that may be required by existing laws and/or the Procuring Entity, such as: <ul style="list-style-type: none">- construction schedule and S-curve;- manpower schedule;- construction methods;- equipment utilization schedule; and- construction safety and health program approved by the DOLE
----	---

Section IV. General Conditions of Contract

Notes on the General Conditions of Contract

The General Conditions of Contract (GCC) in this Section, read in conjunction with the Special Conditions of Contract in Section V and other documents listed therein, should be a complete document expressing all the rights and obligations of the parties.

Matters governing performance of the Contractor, payments under the contract, or matters affecting the risks, rights, and obligations of the parties under the contract are included in the GCC and Special Conditions of Contract.

Any complementary information, which may be needed, shall be introduced only through the Special Conditions of Contract.

1. **Scope of Contract**

This Contract shall include all such items, although not specifically mentioned, that can be reasonably inferred as being required for its completion as if such items were expressly mentioned herein. All the provisions of RA No. 9184 and its 2016 revised IRR, including the Generic Procurement Manual, and associated issuances, constitute the primary source for the terms and conditions of the Contract, and thus, applicable in contract implementation. Herein clauses shall serve as the secondary source for the terms and conditions of the Contract.

This is without prejudice to Sections 74.1 and 74.2 of the 2016 revised IRR of RA No. 9184 allowing the GPPB to amend the IRR, which shall be applied to all procurement activities, the advertisement, posting, or invitation of which were issued after the effectivity of the said amendment.

2. **Sectional Completion of Works**

If sectional completion is specified in the **Special Conditions of Contract (SCC)**, references in the Conditions of Contract to the Works, the Completion Date, and the Intended Completion Date shall apply to any Section of the Works (other than references to the Completion Date and Intended Completion Date for the whole of the Works).

3. **Possession of Site**

4.1. The Procuring Entity shall give possession of all or parts of the Site to the Contractor based on the schedule of delivery indicated in the **SCC**, which corresponds to the execution of the Works. If the Contractor suffers delay or incurs cost from failure on the part of the Procuring Entity to give possession in accordance with the terms of this clause, the Procuring Entity's Representative shall give the Contractor a Contract Time Extension and certify such sum as fair to cover the cost incurred, which sum shall be paid by Procuring Entity.

4.2. If possession of a portion is not given by the above date, the Procuring Entity will be deemed to have delayed the start of the relevant activities. The resulting adjustments in contract time to address such delay may be addressed through contract extension provided under Annex "E" of the 2016 revised IRR of RA No. 9184.

4. **The Contractor's Obligations**

The Contractor shall employ the key personnel named in the Schedule of Key Personnel indicating their designation, in accordance with **ITB** Clause 10.3 and specified in the **BDS**, to carry out the supervision of the Works.

The Procuring Entity will approve any proposed replacement of key personnel only if their relevant qualifications and abilities are equal to or better than those of the personnel listed in the Schedule.

5. Performance Security

- 5.1. Within ten (10) calendar days from receipt of the Notice of Award from the Procuring Entity but in no case later than the signing of the contract by both parties, the successful Bidder shall furnish the performance security in any of the forms prescribed in Section 39 of the 2016 revised IRR.
- 5.2. The Contractor, by entering into the Contract with the Procuring Entity, acknowledges the right of the Procuring Entity to institute action pursuant to RA No. 3688 against any subcontractor be they an individual, firm, partnership, corporation, or association supplying the Contractor with labor, materials and/or equipment for the performance of this Contract.

6. Site Investigation Reports

The Contractor, in preparing the Bid, shall rely on any Site Investigation Reports referred to in the SCC supplemented by any information obtained by the Contractor.

7. Warranty

- 7.1. In case the Contractor fails to undertake the repair works under Section 62.2.2 of the 2016 revised IRR, the Procuring Entity shall forfeit its performance security, subject its property (ies) to attachment or garnishment proceedings, and perpetually disqualify it from participating in any public bidding. All payables of the GOP in his favor shall be offset to recover the costs.
- 7.2. The warranty against Structural Defects/Failures, except that occasioned-on force majeure, shall cover the period from the date of issuance of the Certificate of Final Acceptance by the Procuring Entity. Specific duration of the warranty is found in the SCC.

8. Liability of the Contractor

Subject to additional provisions, if any, set forth in the SCC, the Contractor's liability under this Contract shall be as provided by the laws of the Republic of the Philippines.

If the Contractor is a joint venture, all partners to the joint venture shall be jointly and severally liable to the Procuring Entity.

9. Termination for Other Causes

Contract termination shall be initiated in case it is determined *prima facie* by the Procuring Entity that the Contractor has engaged, before, or during the implementation of the contract, in unlawful deeds and behaviors relative to contract acquisition and implementation, such as, but not limited to corrupt, fraudulent, collusive, coercive, and obstructive practices as stated in ITB Clause 4.

10. Day works

Subject to the guidelines on Variation Order in Annex “E” of the 2016 revised IRR of RA No. 9184, and if applicable as indicated in the **SCC**, the Dayworks rates in the Contractor’s Bid shall be used for small additional amounts of work only when the Procuring Entity’s Representative has given written instructions in advance for additional work to be paid for in that way.

11. Program of Work

11.1. The Contractor shall submit to the Procuring Entity’s Representative for approval the said Program of Work showing the general methods, arrangements, order, and timing for all the activities in the Works. The submissions of the Program of Work are indicated in the **SCC**.

11.2. The Contractor shall submit to the Procuring Entity’s Representative for approval an updated Program of Work at intervals no longer than the period stated in the **SCC**. If the Contractor does not submit an updated Program of Work within this period, the Procuring Entity’s Representative may withhold the amount stated in the **SCC** from the next payment certificate and continue to withhold this amount until the next payment after the date on which the overdue Program of Work has been submitted.

12. Instructions, Inspections and Audits

The Contractor shall permit the GOP or the Procuring Entity to inspect the Contractor’s accounts and records relating to the performance of the Contractor and to have them audited by auditors of the GOP or the Procuring Entity, as may be required.

13. Advance Payment

The Procuring Entity shall, upon a written request of the Contractor which shall be submitted as a Contract document, make an advance payment to the Contractor in an amount not exceeding fifteen percent (15%) of the total contract price, to be made in lump sum, or at the most two installments according to a schedule specified in the **SCC**, subject to the requirements in Annex “E” of the 2016 revised IRR of RA No. 9184.

14. Progress Payments

The Contractor may submit a request for payment for Work accomplished. Such requests for payment shall be verified and certified by the Procuring Entity’s Representative/Project Engineer. Except as otherwise stipulated in the **SCC**, materials and equipment delivered on the site but not completely put in place shall not be included for payment.

15. Operating and Maintenance Manuals

15.1. If required, the Contractor will provide “as built” Drawings and/or operating and maintenance manuals as specified in the **SCC**.

- 15.2. If the Contractor does not provide the Drawings and/or manuals by the dates stated above, or they do not receive the Procuring Entity's Representative's approval, the Procuring Entity's Representative may withhold the amount stated in the **SCC** from payments due to the Contractor.

Section V. Special Conditions of Contract

Notes on the Special Conditions of Contract

Similar to the BDS, the clauses in this Section are intended to assist the Procuring Entity in providing contract-specific information in relation to corresponding clauses in the GCC found in Section IV.

The Special Conditions of Contract (SCC) complement the GCC, specifying contractual requirements linked to the special circumstances of the Procuring Entity, the Procuring Entity's country, the sector, and the Works procured. In preparing this Section, the following aspects should be checked:

- a. Information that complements provisions of the GCC must be incorporated.
- b. Amendments and/or supplements to provisions of the GCC as necessitated by the circumstances of the specific purchase, must also be incorporated.

However, no special condition which defeats or negates the general intent and purpose of the provisions of the GCC should be incorporated herein.

Special Conditions of Contract

GCC Clause	
1	<p>The works shall consist of completion of building structures including:</p> <ol style="list-style-type: none"> 1. Project Billboard /Sign Board 2. Occupational Safety and Health Program 3. Mobilization and Demobilization 4. Wall Tiles (Glazed Tiles and Trims) 5. Floor Tiles (Unglazed Tiles and Trims) 6. Hardiflex on Metal Frame Ceiling 7. Electrical Works 8. Metal Railings / Window Grills 9. Painting Works (Masonry Painting) 10. Painting Works (Ceiling) 11. Painting Works (Metal Painting) 12. Aluminum Glass Door (Sliding /Awning)
2	<p>Sectional completion is not applicable.</p> <p>The intended completion of the project is within <i>Twenty-four (24)</i> calendar days upon receipt of the Notice to Proceed</p>
4.1	<p>The Procuring Entity shall give possession of all parts of the Site to the Contractor upon receipt of the Notice to Proceed.</p>
7.2	<p>[In case of semi-permanent structures, such as buildings of types 1, 2, and 3 as classified under the National Building Code of the Philippines, concrete/asphalt roads, concrete river control, drainage, irrigation lined canals, river landing, deep wells, rock causeway, pedestrian overpass, and other similar semi-permanent structures:] Five (5) years.</p>
10	<p>Dayworks are applicable at the rate shown in the Contractor's original Bid.</p>
11.1	<p>The Contractor shall submit the Program of Work to the Procuring Entity's representative within ten (10) calendar days of delivery of the Notice of Award.</p> <p>The Program of Work shall be updated and shall be submitted to Procuring Entity's assigned Project Manager for approval:</p> <ul style="list-style-type: none"> - On the first working day of the week following a Weekly Accomplishment Report indicating the slippage; and - Together with the request for Variation Orders, either in the form of a change order or extra work order, that shall cover any increase or decrease in the original quantities of the Contract.
11.2	<p>The amount to be withheld for late submission of an updated Program of Work is at least equal to one-tenth (1/10) of one percent (1%) of the cost of the unperformed portion for every day of delay.</p>

13	The amount of the advance payment is 15% percent of the contract price.		
14	The terms of payment shall be as follows:		
	Payment/Progress Billing	Description	Weight
	Advance Payment	15% of the contract cost	-
	Accomplishment of 20%	Contractor may bill 20% of the contract cost	20%
	Accomplishment of 40%	Contractor may bill 20% of the contract cost	20%
	Accomplishment of 50%	Contractor may bill 10% of the contract cost	10%
	Accomplishment of 60%	Contractor may bill 10% of the contract cost	10%
	Accomplishment of 70%	Contractor may bill 10% of the contract cost	10%
	Accomplishment of 80%	Contractor may bill 10% of the contract cost	10%
	Accomplishment of 90%	Contractor may bill 10% of the contract cost	10%
	Accomplishment of 100%	Contractor may bill 10% of the contract cost	10%
		TOTAL	100%
15.1	The As-Built Drawings shall be required before the issuance of a Certificate of Completion.		
15.2	The final payment shall be withheld for failing to submit the complete set of As-Built Drawings.		

Section VI. Specifications

Notes on Specifications

A set of precise and clear specifications is a prerequisite for Bidders to respond realistically and competitively to the requirements of the Procuring Entity without qualifying or conditioning their Bids. In the context of international competitive bidding, the specifications must be drafted to permit the widest possible competition and, at the same time, present a clear statement of the required standards of workmanship, materials, and performance of the goods and services to be procured. Only if this is done will the objectives of economy, efficiency, and fairness in procurement be realized, responsiveness of Bids be ensured, and the subsequent task of bid evaluation facilitated. The specifications should require that all goods and materials to be incorporated in the Works be new, unused, of the most recent or current models, and incorporate all recent improvements in design and materials unless provided otherwise in the Contract.

Samples of specifications from previous similar projects are useful in this respect. The use of metric units is mandatory. Most specifications are normally written specially by the Procuring Entity or its representative to suit the Works at hand. There is no standard set of Specifications for universal application in all sectors in all regions, but there are established principles and practices, which are reflected in these PBDs.

There are considerable advantages in standardizing General Specifications for repetitive Works in recognized public sectors, such as highways, ports, railways, urban housing, irrigation, and water supply, in the same country or region where similar conditions prevail. The General Specifications should cover all classes of workmanship, materials, and equipment commonly involved in construction, although not necessarily to be used in a particular Works Contract. Deletions or addenda should then adapt the General Specifications to the particular Works.

Care must be taken in drafting specifications to ensure that they are not restrictive. In the specification of standards for goods, materials, and workmanship, recognized international standards should be used as much as possible. Where other particular standards are used, whether national standards or other standards, the specifications should state that goods, materials, and workmanship that meet other authoritative standards, and which ensure substantially equal or higher quality than the standards mentioned, will also be acceptable. The following clause may be inserted in the SCC.

Sample Clause: Equivalency of Standards and Codes

Wherever reference is made in the Contract to specific standards and codes to be met by the goods and materials to be furnished, and work performed or tested, the provisions of the latest current edition or revision of the relevant standards and codes in effect shall apply, unless otherwise expressly stated in the Contract. Where such standards and codes are national, or relate to a particular country or region, other authoritative standards that ensure a substantially equal or higher quality than the standards and codes specified will be accepted

subject to the Procuring Entity's Representative's prior review and written consent. Differences between the standards specified and the proposed alternative standards shall be fully described in writing by the Contractor and submitted to the Procuring Entity's Representative at least twenty-eight (28) days prior to the date when the Contractor desires the Procuring Entity's Representative's consent. In the event the Procuring Entity's Representative determines that such proposed deviations do not ensure substantially equal or higher quality, the Contractor shall comply with the standards specified in the documents.

These notes are intended only as information for the Procuring Entity or the person drafting the Bidding Documents. They should not be included in the final Bidding Documents.

S P E C I F I C A T I O N S

Electrical Works

- o All electrical works herein shall be done in accordance with these plans and specifications, the applicable provisions of the latest edition of the Philippine Electrical Code, the rules and regulations of the local enforcing authority and the requirements of the local power and telephone companies. The electrical works shall be under immediate supervision of a duly licensed Electrical Engineer.
- o Power service to the building shall be 230 volts, 1-phase 60HZ, AC power source, 3-wire + 1-ground.
- o All electrical wiring installation such as lighting, power, fire alarm & CCTV system to be used shall be polyvinyl chloride (PVC) pipe. "Schedule 40"
- o Unless otherwise specified, the minimum size of wire shall be 3.5mm TW/THHN2
- o and conduit shall be 20mmø electrical trade size.
- o All wire shall be copper and thermoplastic insulated type "THHN/THWN" unless otherwise indicated in the plans and shall be manufactured by Phelps dodge or approval equal.
- o All outlet boxes shall be galvanized gauge no. 16, deep type with factory knockouts. Cover all junction boxes (no exposed wire)
- o Panelboards shall be of dead-front type construction with adequate wire space, surface mounted, finished in industrial grey enamel over a coat or rust inhibitor. Minimum thickness shall be 1.4mm (GA 16). Circuit breakers shall be quick-make, quick break, trip-free on overload and short-circuit edition, bolt-on type. All circuit breakers and panelboard shall be "G.E or square-D".
- o All wiring devices shall be "National" or approved equal.
- o All materials to be used shall be brand new and must be approved type for the particular location and purpose intended.
- o Provide grounding system to all lighting and power circuit as per Philippine Electrical Code requirement.
- o Mounting heights are: (Subject to Architect's approval)
 - A. Light Switches — 1.20M above floor finish
 - B. Convenience Outlets — 0.30M above floor finish
 - C. Telephone Outlets — 0.30M above floor finish
 - D. Panelboard — 1.40M above floor finish
 - E. Emergency Light — 0.30M below ceiling line
 - F. Data Outlet — 0.30M below ceiling line
- o Pull boxes shall be used when applicable for easy pulling of wires and shall be according to code requirement. All fluorescent ballast shall be high power factor, rapid start, spring loaded lamp holder and enclosed in metallic box.
- o Provide flexible metal conduit and sufficient mica tube from junction boxes to lighting fixtures.

Architectural works

- o All interior ceiling using hardiflex finished with paints. Ceiling joist and framings using metal furring metal furring and metals stud.
- o Windows and window frame shall conform sized, design and kinds of materials shown in the details of windows, schedule of windows or as per the bill of materials.
- o The materials for the floor finishes shall be plain plastered cement finish for the provision of floor tiles finishes for phase
- o The toilet and bathroom shall be finished unglazed. The walls of the toilet and bathrooms shall be with 30cm x 30cm ceramic tiles and for the floor tiles is 60cm x 60cm ceramic tiles.
- o All painting works for this project, except as hereinafter specified, shall be done with the use of BOYSEN PAINTS. Skim coat application for all the masonry finishes before the final coat applications.

FABRICATION

- A Generally: Fabricate handrails and railing systems to design, dimensions and details shown. Provide handrail and railing members in sizes and profiles indicated, with supporting posts and brackets or size and spacing shown, but not less than required to comply with requirements indicated for structural performance.
- B Shop Assembly: Pre-assemble items in shop to greatest extent possible to minimize field splicing and assembly. Disassemble units only as necessary for shipping and handling limitations. Clearly mark units for reassembly and coordinated installation.
- C Welded Connections: Fabricate handrails and railing systems of materials indicated below for interconnections of members of welding. Use welding method, which is appropriate for metal and finish, indicated and develops strength required to comply with structural performance criteria. Finish exposed welds and surfaces smooth, flush, and blended to match adjoining surfaces. Form changes in direction of railing members by bending members by metering, or as indicated on the drawing, as approved by the Architect. Furnish inserts and other anchorage devices for connecting handrails and railing systems to concrete or masonry work. Fabricate anchorage devices, which are capable of withstanding loading imposed by handrails and railing systems. Coordinate anchorage devices with supporting structure. For railing posts set in concrete provide pre-chiseled openings and insert posts as indicated on drawings. Fill opening with non-shrink, non-metallic grout.

Section VII. Drawings



[Insert here a list of Drawings. The actual Drawings, including site plans, should be attached to this section, or annexed in a separate folder.]



VICINITY MAP

PROJECT SITE

LOCATION: FP2X + HQ8, Ave of the Philippines, Freeport Area of Batavia, Marikina City, Batangas
 14°27'04.7"N
 120°29'58"E

PICTURES

ITEM NO.	DESCRIPTION	UNIT	QTY.
B.5	Project Billboard/Sign Board	sqm	64
B.7(1)	Occupational Safety and Health Program	Man-Days	211
B.9	Mobilization and Demobilization	Days	2
100(1)	Wall Tiles (Glazed Tiles and Trims)	sqm	2018
100(1P)	Floor Tiles (Ungrazed Tiles and Trims)	sqm	1021205
100(1B)	Hardflox on Metal Frame Ceiling	sqm	115099
900(1)	Electrical Works	sqm	1354
901(1)	Metal Rollings/Window Grills	sqm	1307
102(1P)	Painting Works (Seasonal Painting)	sqm	241308
102(1B)	Painting Works (Ceiling)	sqm	112128
102(1C)	Painting Works (Metal Painting)	sqm	202725
102(1X)	Aluminum Glass Door/Sliding /Awning	sqm	13863

THE CONTRACTOR SHALL BE RESPONSIBLE FOR OBTAINING ALL NECESSARY PERMITS AND APPROVALS FROM THE LOCAL GOVERNMENT AND ALL AGENCIES OF THE GOVERNMENT.

THE CONTRACTOR SHALL BE RESPONSIBLE FOR OBTAINING ALL NECESSARY PERMITS AND APPROVALS FROM THE LOCAL GOVERNMENT AND ALL AGENCIES OF THE GOVERNMENT.

THE CONTRACTOR SHALL BE RESPONSIBLE FOR OBTAINING ALL NECESSARY PERMITS AND APPROVALS FROM THE LOCAL GOVERNMENT AND ALL AGENCIES OF THE GOVERNMENT.

OFFICE OF THE ASSISTANT
PROVINCIAL ENGINEER
OFFICE OF THE MUNICIPAL ENGINEER
MUNICIPALITY OF BATAVIA

PROJECT TITLE
**COMPLETION OF MULTI-PURPOSE BUILDING
AT BPO7, BATAVIA, MARIKINA CITY, BATANGAS**

DESIGNED BY
YASMINA M. TORRES
REGISTERED CIVIL ENGINEER

APPROVED BY
EDUARDO M. TORRES
REGISTERED CIVIL ENGINEER

REGISTERED PROFESSIONAL
LEONARDO M. TORRES
REGISTERED CIVIL ENGINEER

APPROVED BY
ATTY. ANTONIO C. CONCEPCION
REGISTERED ATTORNEY

DATE OF CONTRACT
SEPTEMBER 2023

SCALE
1/6

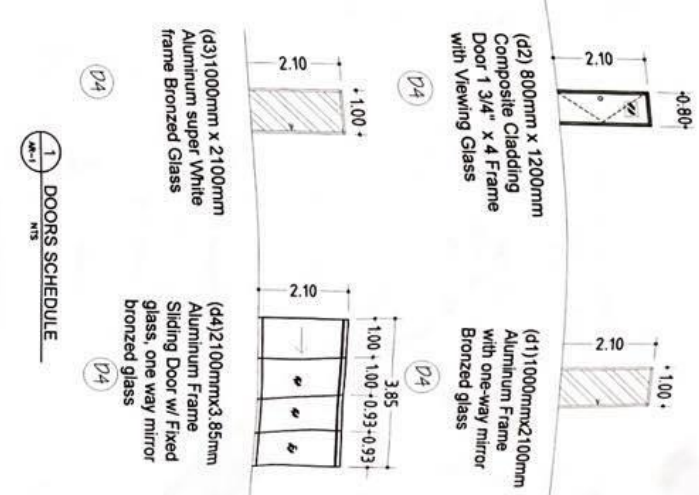
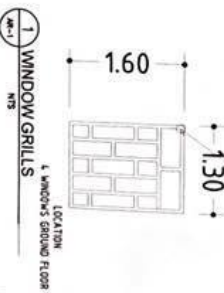
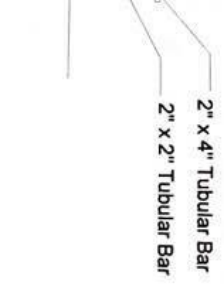
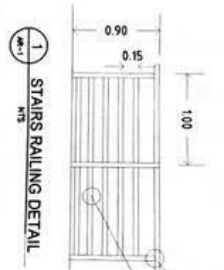
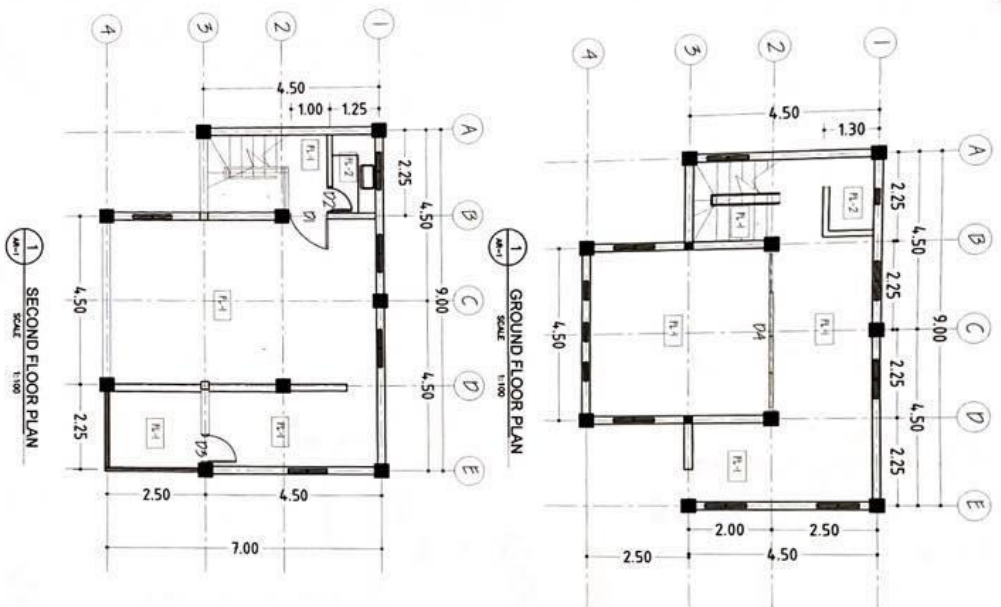

	OFFICE OF THE MUNICIPAL ENGINEER MUNICIPALITY OF MARIKINA	PROJECT TITLE COMPLETION OF MULTI PURPOSE BUILDING AT BORT MARIKINA, MARIKINA, BULACAN	PREPARED BY 	CHECKED BY 	APPROVED BY 	DATE 2/6
	OFFICE OF THE MUNICIPAL ENGINEER MUNICIPALITY OF MARIKINA	PROJECT TITLE COMPLETION OF MULTI PURPOSE BUILDING AT BORT MARIKINA, MARIKINA, BULACAN	PREPARED BY 	CHECKED BY 	APPROVED BY 	DATE 2/6

 OFFICE OF THE MUNICIPAL ENGINEER PROVINCE OF MARIKINA MUNICIPALITY OF MARIKINA	PROJECT TITLE	APPROVED BY:	DATE
	COMPLETION OF MULTI-PURPOSE BUILDING AT BRGY. MARIKINA, MARIKINA, BATAK	 ATTY. ACE JELLIO C. CONCEPTION MUNICIPAL ATTORNEY	3/6
ENGINEER IN CHARGE  ENGR. ORLINA Y. SISON REGISTERED PROFESSIONAL ENGINEER	APPROVED BY:  ENGR. ORLINA Y. SISON REGISTERED PROFESSIONAL ENGINEER	CHECKED BY:  ENGR. ORLINA Y. SISON REGISTERED PROFESSIONAL ENGINEER	

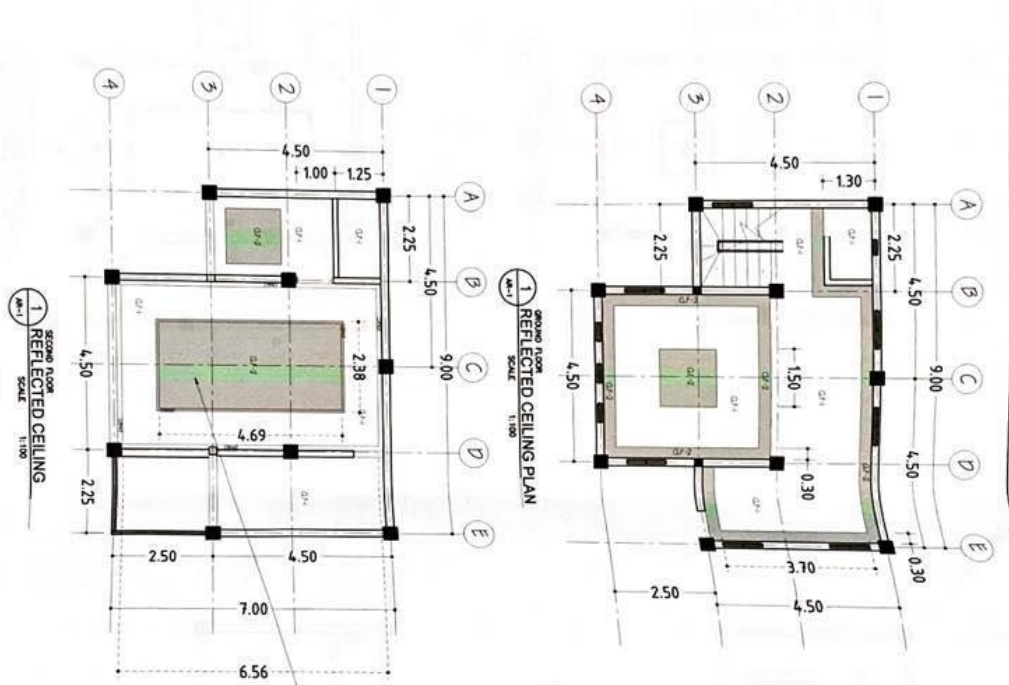

CLF-1: 1/2" THICK HARDPLEX CEILING BOARD (PAINTED)
 ON METAL FLOORING CHANNEL @ 400 MM OC
 HEIGHT: 270 MM

CLF-2: 1/2" THICK HARDPLEX CEILING BOARD (PAINTED)
 ON METAL FLOORING CHANNEL @ 400 MM OC
 HEIGHT: 260 MM

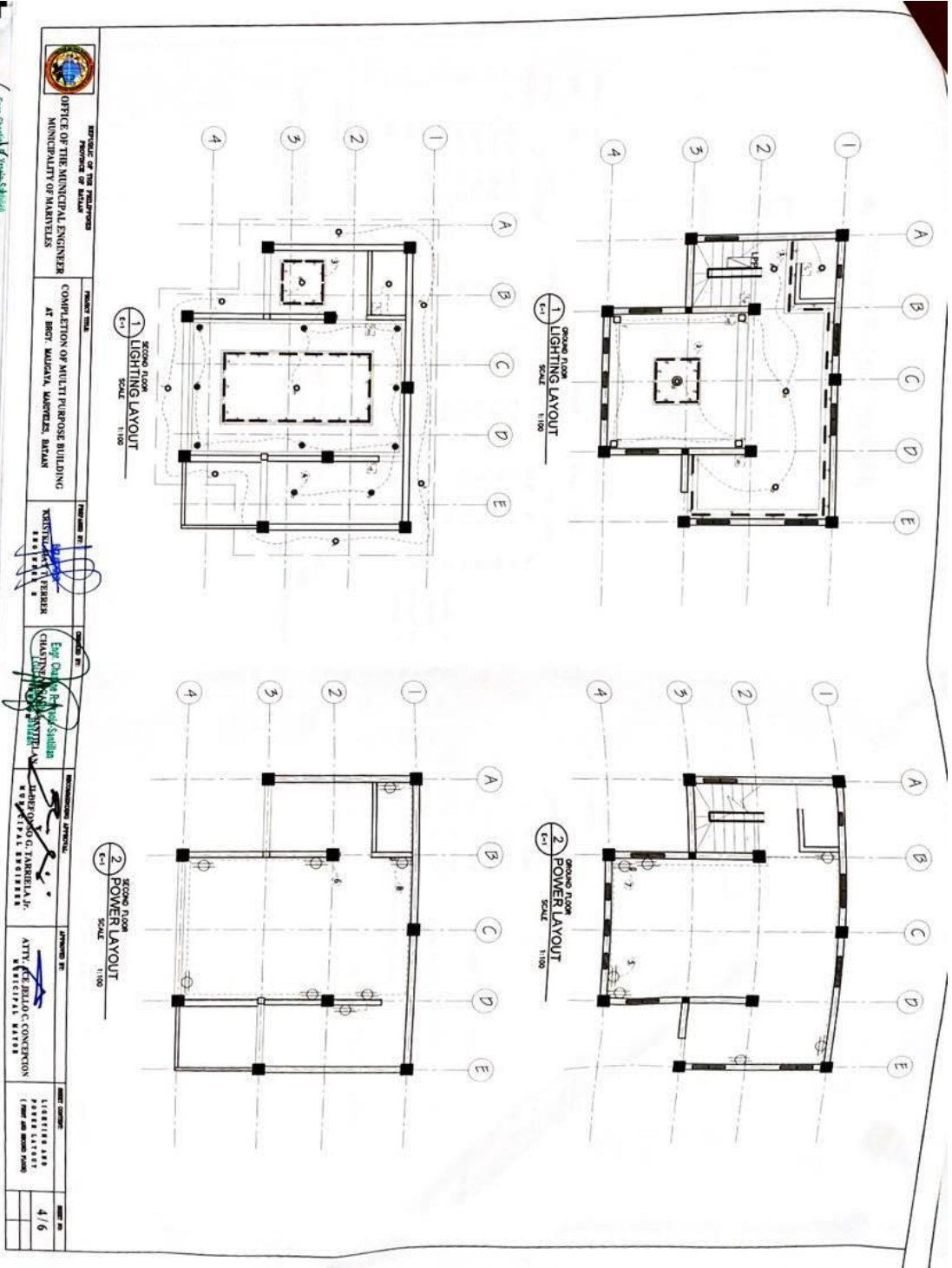

OFFICE OF THE MUNICIPAL ENGINEER
PROVINCE OF BULACAN
MUNICIPALITY OF MARIKINA

PROJECT TITLE
COMPLETION OF MULTI-PURPOSE BUILDING
AT BRD. MARIKINA, MARIKINA, BULACAN

DESIGNED BY
KERRYLLA T. VERBERE

CHECKED BY
Engr. Danilo P. Sison
CHAIRMAN, MARIKINA CITY ENGINEERING BOARD

REVISIONS APPROVAL
MARCO ANTONIO G. TARRIBELLA, JR.
MUNICIPAL ENGINEER

APPROVED BY
ATTY. REYNOLD C. GONZALEZ
MUNICIPAL ATTORNEY

DATE COMPLETED
MAY 14, 2024

SHEET NO.
4 / 6

- 10watts Pinlight (daylight)
- 18WATTS LED RECESSED SLIM DOWNLIGHT DAY LIGHT
- 10watts square Panel Light (daylight)
- ▬ 8watts t5 cover light (warmlight)

CIRCUIT NUMBER	LOAD DESCRIPTION	CONNECTED LOAD	LOAD VOLTAGE	AMPERE	PROTECTION			WIRE	CONDUIT
					AI	AF	WF		
1	LIGHTING OUTLET	1700	230	7.39	2	15	50	2-15mm ² THHN wire	1/2" dia. per conduit
2	LIGHTING OUTLET	1600	230	6.96	2	15	50	2-15mm ² THHN wire	1/2" dia. per conduit
3	LIGHTING OUTLET	2200	230	9.57	2	15	50	2-15mm ² THHN wire	1/2" dia. per conduit
4	LIGHTING OUTLET	2200	230	9.57	2	15	50	2-15mm ² THHN wire	1/2" dia. per conduit
5	CONVENIENCE OUTLET	720	230	3.13	2	20	50	2-15mm ² THHN wire + 1-20 mm ² THHN/THWN	1/2" dia. per conduit
6	CONVENIENCE OUTLET	1080	230	4.70	2	20	50	2-15mm ² THHN wire + 1-20 mm ² THHN/THWN	1/2" dia. per conduit
7	ACU	3000	230	13.04	2	30	50	2-25mm ² THHN wire + 1-35 mm ² THHN/THWN	1/2" dia. per conduit
8	ACU	3000	230	13.04	2	30	50	2-25mm ² THHN wire + 1-35 mm ² THHN/THWN	1/2" dia. per conduit
TOTAL:		13,040		54.36					

PANEL : LPFC
WIRE : 2W + 1G
VOLTAGE : 230V
PHASE : SINGLE PHASE
ENCLOSURE : NEMA1
MOUNTING : SURFACE MOUNTED

USE: 75A1T, 1PHASE, 2POLE, 230V, BOLT-ON,
MAIN CB INSIDE 10 BRANCHES PANEL BOARD
USE: 2-22mm² THHN CU wire + 1-5 5mm² THHN CU wire (G) feeder line

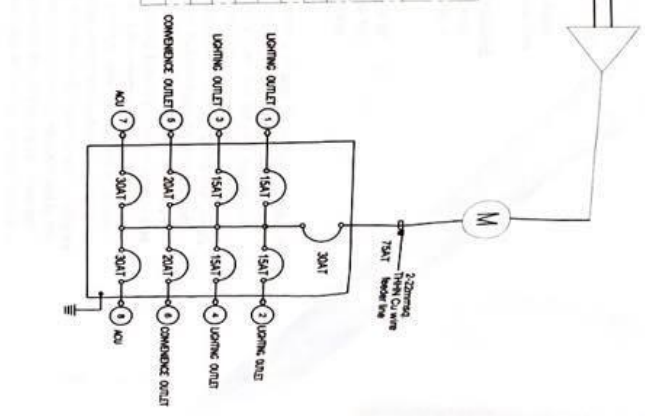

 REPUBLIC OF THE PHILIPPINES PROVINCE OF RIZAL OFFICE OF THE MUNICIPAL ENGINEER MUNICIPALITY OF MARIKINA	PROJECT TITLE	DESIGNED BY	CHECKED BY	REVISIONS APPROVAL	APPROVED BY	DATE
	COMPLETION OF MULTI PURPOSE BUILDING AT BPO, MARIKINA, MARIKINA, BATAVIA	CHRISTOPHER M. VILLAR REGISTERED ELECTRICAL ENGINEER	DR. DANIELA M. SORIANO REGISTERED ELECTRICAL ENGINEER	DR. DANIELA M. SORIANO REGISTERED ELECTRICAL ENGINEER	DR. DANIELA M. SORIANO REGISTERED ELECTRICAL ENGINEER	DR. DANIELA M. SORIANO REGISTERED ELECTRICAL ENGINEER

Section VIII. Bill of Quantities

Notes on the Bill of Quantities

Objectives

The objectives of the Bill of Quantities are:

- a. to provide sufficient information on the quantities of Works to be performed to enable Bids to be prepared efficiently and accurately; and
- b. when a Contract has been entered into, to provide a priced Bill of Quantities for use in the periodic valuation of Works executed.

In order to attain these objectives, Works should be itemized in the Bill of Quantities in sufficient detail to distinguish between the different classes of Works, or between Works of the same nature carried out in different locations or in other circumstances which may give rise to different considerations of cost. Consistent with these requirements, the layout and content of the Bill of Quantities should be as simple and brief as possible.

Daywork Schedule

A Daywork Schedule should be included only if the probability of unforeseen work, outside the items included in the Bill of Quantities, is high. To facilitate checking by the Entity of the realism of rates quoted by the Bidders, the Daywork Schedule should normally comprise the following:

- a. A list of the various classes of labor, materials, and Constructional Plant for which basic daywork rates or prices are to be inserted by the Bidder, together with a statement of the conditions under which the Contractor will be paid for work executed on a daywork basis.
- b. Nominal quantities for each item of Daywork, to be priced by each Bidder at Daywork rates as Bid. The rate to be entered by the Bidder against each basic Daywork item should include the Contractor's profit, overheads, supervision, and other charges.

Provisional Sums

A general provision for physical contingencies (quantity overruns) may be made by including a provisional sum in the Summary Bill of Quantities. Similarly, a contingency allowance for possible price increases should be provided as a provisional sum in the Summary Bill of Quantities. The inclusion of such provisional sums often facilitates budgetary approval by avoiding the need to request periodic supplementary approvals as the future need arises. Where such provisional sums or contingency allowances are used, the SCC should state the manner in which they will be used, and under whose authority (usually the Procuring Entity's Representative's).

The estimated cost of specialized work to be carried out, or of special goods to be supplied, by other contractors should be indicated in the relevant part of the Bill of Quantities as a particular provisional sum with an appropriate brief description. A separate procurement procedure is normally carried out by the Procuring Entity to select such specialized contractors. To provide an element of competition among the Bidders in respect of any facilities, amenities, attendance, etc., to be provided by the successful Bidder as prime Contractor for the use and convenience of the specialist contractors, each related provisional sum should be followed by an item in the Bill of Quantities inviting the Bidder to quote a sum for such amenities, facilities, attendance, etc.

Signature Box

A signature box shall be added at the bottom of each page of the Bill of Quantities where the authorized representative of the Bidder shall affix his signature. Failure of the authorized representative to sign each and every page of the Bill of Quantities shall be a cause for rejection of his bid.

These Notes for Preparing a Bill of Quantities are intended only as information for the Procuring Entity or the person drafting the Bidding Documents. They should not be included in the final documents.



Republic of the Philippines
Province of Bataan
Municipality of Mariveles



Office of the Municipal Engineer

APPROVED BUDGET FOR THE CONTRACT
COMPLETION OF MULTI-PURPOSE BUILDING
AT BRGY.MALIGAYA MARIVELES, BATAAN

IMPLEMENTING OFFICE	MUNICIPAL ENGINEER'S OFFICE	IMPLEMENTATION PROCEDURE	()	ADMIN
NAME OF PROJECT	COMPLETION OF MULTI-PURPOSE BUILDING		(✓)	CONTRACT
LOCATION	AT BRGY.MALIGAYA MARIVELES, BATAAN	CALENDAR DAYS TO COMPLETE	24	DAYS
APPROPRIATION/ AMOUNT	700,000.00			

SUMMARY/ESTIMATED

ITEM NO.	DESCRIPTION	UNIT	QTY.	TOTAL AMOUNT	UNIT PRICE
B.5	Project Billboard/Sign Board	sq.ft	64		
B.7(1)	Occupational Safety and health Program	Man-Days	211		
B.9	Mobilization and Demobilization	Days	2		
100(1)	Wall Tiles (Glazed Tiles and Trims)	sq.m	20.18		
100(1)d	Floor Tiles (Unglazed Tiles and Trims)	sq.m	102.1325		
103(1)a	Hardiflex on Metal Frame Ceiling	sq.m	115.099		
900(1)	Electrical Works	sq.m	135.54		
901(1)	Metal Railings/Window Grills	sq.m	13.07		
1032(1)a	Painting Works (Masonry Painting)	sq.m	241.598		
1032(1)b	Painting Works (Ceiling)	sq.m	112.139		
1032(1)c	Painting Works (Metal Painting)	sq.m	20.2755		
1007	Aluminum Glass Door(Sliding /Awning)	sq.m	13.965		

Prepared By:

KRISTEL MAY T. FERRER
ENGINEER II

Recommending Approval:

EDELFONSO G. BARRIELA JR.
MUNICIPAL ENGINEER

Checked by:

CHASTINE R. YRAOLA SANTILLAN
MGADH

Approved by:

ATTY. ACE JELLO C. CONCEPCION
MUNICIPAL MAYOR

Section IX. Checklist of Technical and Financial Documents

Notes on the Checklist of Technical and Financial Documents

The prescribed documents in the checklist are mandatory to be submitted in the Bid, but shall be subject to the following:

- a. GPPB Resolution No. 09-2020 on the efficient procurement measures during a State of Calamity or other similar issuances that shall allow the use of alternate documents in lieu of the mandated requirements; or
- b. any subsequent GPPB issuances adjusting the documentary requirements after the effectivity of the adoption of the PBDs.

The BAC shall be checking the submitted documents of each Bidder against this checklist to ascertain if they are all present, using a non-discretionary “pass/fail” criterion pursuant to Section 30 of the 2016 revised IRR of RA No. 9184.

Checklist of Technical and Financial Documents

I. TECHNICAL COMPONENT ENVELOPE

Class “A” Documents

Legal Documents

- (a) Valid PhilGEPS Registration Certificate (Platinum Membership) (all pages);
or
- (b) Registration certificate from Securities and Exchange Commission (SEC), Department of Trade and Industry (DTI) for sole proprietorship, or Cooperative Development Authority (CDA) for cooperatives or its equivalent document;
and
- (c) Mayor’s or Business permit issued by the city or municipality where the principal place of business of the prospective bidder is located, or the equivalent document for Exclusive Economic Zones or Areas;
and
- (e) Tax clearance per E.O. No. 398, s. 2005, as finally reviewed and approved by the Bureau of Internal Revenue (BIR).

Technical Documents

- (f) Statement of the prospective bidder of all its ongoing government and private contracts, including contracts awarded but not yet started, if any, whether similar or not similar in nature and complexity to the contract to be bid; **and**
- (g) Statement of the bidder’s Single Largest Completed Contract (SLCC) similar to the contract to be bid, except under conditions provided under the rules;
and
- (h) Philippine Contractors Accreditation Board (PCAB) License;
or
Special PCAB License in case of Joint Ventures;
and registration for the type and cost of the contract to be bid; **and**
- (i) Original copy of Bid Security. If in the form of a Surety Bond, submit also a certification issued by the Insurance Commission;
or
Original copy of Notarized Bid Securing Declaration; **and**
- (j) Project Requirements, which shall include the following:
 - a. Organizational chart for the contract to be bid;
 - b. List of contractor’s key personnel (*e.g.*, Project Manager, Project Engineers, Materials Engineers, and Foremen), to be assigned to the contract to be bid, with their complete qualification and experience data;
 - c. List of contractor’s major equipment units, which are owned, leased, and/or under purchase agreements, supported by proof of ownership or certification of availability of equipment from the equipment lessor/vendor for the duration of the project, as the case may be; **and**

- (k) Original duly signed Omnibus Sworn Statement (OSS); **and** if applicable, Original Notarized Secretary's Certificate in case of a corporation, partnership, or cooperative; or Original Special Power of Attorney of all members of the joint venture giving full power and authority to its officer to sign the OSS and do acts to represent the Bidder.

Financial Documents

- (l) The prospective bidder's audited financial statements, showing, among others, the prospective bidder's total and current assets and liabilities, stamped "received" by the BIR or its duly accredited and authorized institutions, for the preceding calendar year which should not be earlier than two (2) years from the date of bid submission; **and**
- (m) The prospective bidder's computation of Net Financial Contracting Capacity (NFCC).

Class "B" Documents

- (n) If applicable, duly signed joint venture agreement (JVA) in accordance with RA No. 4566 and its IRR in case the joint venture is already in existence; **or** duly notarized statements from all the potential joint venture partners stating that they will enter into and abide by the provisions of the JVA in the instance that the bid is successful.

II. FINANCIAL COMPONENT ENVELOPE

- (o) Original of duly signed and accomplished Financial Bid Form; **and**

Other documentary requirements under RA No. 9184

- (p) Original of duly signed Bid Prices in the Bill of Quantities; **and**
- (q) Duly accomplished Detailed Estimates Form, including a summary sheet indicating the unit prices of construction materials, labor rates, and equipment rentals used in coming up with the Bid;
- (r) Cash Flow by Quarter;
- (s) Manpower and Equipment Utilization;
- (t) Construction Methodology, BarChart, S-curve and PERT-CPM.

